

Virutex Edge Banders

Operating Manual Model EB25

1- Initial Set up

2- Learn the machine (do not turn the machine on)

- 2.1 - Feeding the tape in, adjusting for different tape widths
- 2.2 - Feeding the board and adjusting for board thickness
- 2.3 - Front and back flush cut blade sets
- 2.4 - Top+Bottom motorized flush trim station

3- Control Panel

4- Power Feeder

5- Test runs to find the right temperature

6- Cleaning the machine

- Trim Station Blades, Front Blades, Back Blades, tape in feed track

7- Changing spare parts (also see video)

- 7.1- Tape in feed track assembly
- 7.2- Top+ Bottom Trim Station
 - Carbon Brushes
 - Blades
 - Belts
 - Motor
- 7.3- Power feeder
 - Belt
- 7.4- Lifting Center Deck of the machine for changing:
 - Back Cut Blades Section: blades, magnet, blade return spring
 - Heater
 - Micro switched located on the deck
- 7.5- Front Blades Assembly
 - Front Blades
 - Magnet
 - Blade return spring
 - micro switch

8- Trouble Shooting

- 8.1 - If heater does not work
- 8.2 - If tape does not cover the board
- 8.3 - If Front cut has over hang, or tape folds over the board, or if it cuts half way and jams (blades on the left when facing the machine)
- 8.4 - When back cut has over hang
- 8.5 - When part of the board does not get a good bond
- 8.6 - If any of front or back blades close but do not return back to open position

Initial Set Up (15 minutes)

When you receive the crate, you need to assemble the extensions, and wire the plug.
220 Volts, single phase, 20 dedicated Amps.
The machine is pre-set at the factory for 3/4" board and 7/8" wide tape.
Please read the instructions before you operate the machine

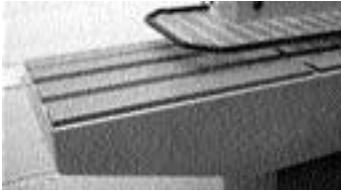

A- Screw in the two end table extensions

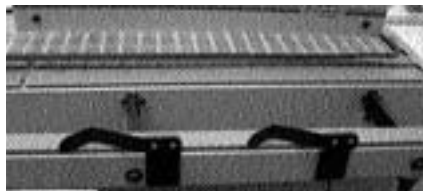

B- Install front fence lateral extensions and two cross bars



C & D Install bracket and tape Tray



E- Wire the blue plug 220 Volts single phase 15 Amps



2- Learn the machine (do not turn the machine on)

It takes about 15 minutes to learn different functions of the machine. Do not turn the machine on. feed the tape in, swing open the feeder. Take a board trough the machine, as if you are the feeder, and see how every thing works in an open and slow mode.

- 2.1 - Feeding the tape in
- 2.2 - Adjusting for board thickness / tape width & board+ tape infeed system
- 2.3 - Front and back flush cut blade sets
- 2.4 - Top+Bottom motorized flush trim station

2.1 - Feed the tape into machine



Place the roll on tape holder

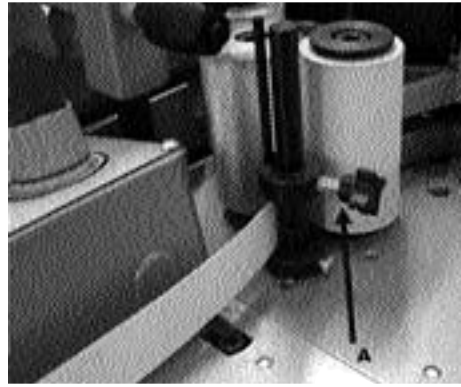

Knob **A** should be about 1/32" or 0.8 mm above the tape to regulate height movement



Stop the tape at the tip of the back blade set located under the protective cover

2.2 - Adjusting for board thickness / tape widths

The machine is pre set at the factory for 3/4" wide board which requires 7/8" wide tape. **The tape must always be 1/8" wider than the board.**

It would take less than 5 minutes to adjust the machine for different board thickness. To make adjustments::



Tape Tracking Guide

Move top knob up or down to be 1/32" higher than the tape. Top & bottom tracks prevent tape from moving up or down & should hug the tape loosely. Push tape thought tracks manually to assure smooth pass

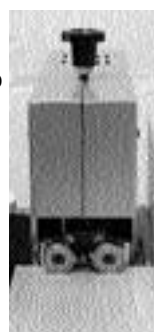

Top & Bottom Trim Station

Turn knob for a tight hug of the board. Need not be precise Spring loaded bearing guides self adjust blade heights. See page 4 for details



Power Feeder

Use side handle to unlock feeder. Turn top handle to adjust height based on scale on side of column. see page 5 for more details

Board & tape infeed system

The power feeder takes the board through the machine automatically.

BUT

We recommend you first take the board through the in-feed section by hand.

This way you can see how the board is pulling the tape into the machine.

- 1- Open the power feeder. The machine shuts off when feeder is opened.
- 2- Push the board against the metallic fence **A** and move forward as shown with arrows.
The board should be pushed left into the machine, and yet be pressed completely against the fence **A**
The board will then hit and turn the metallic roller **B** which activates the infeed of tape.
The entire length of board should press against the metallic roller **B**
- 3- Metal plate **C** pre-heats the board without direct contact.
- 4- The tip of the board will then pick up the tape right at rubber roller **D** and will continue to pull the tape from there on. The glue is already melted when the tape reaches roller **D**
- 5- The board will then enter the top+bottom motorized trimming station.

Do not take the board into the top+bottom trimming station manually.
You will find it hard to push the board manually through the top+bottom bearing guides of trimming station because a tight grip is required.
However, the power feeder will do that with no problem.
This station is pre-set at the factory for 3/4" thick board, and 7/8" tape.

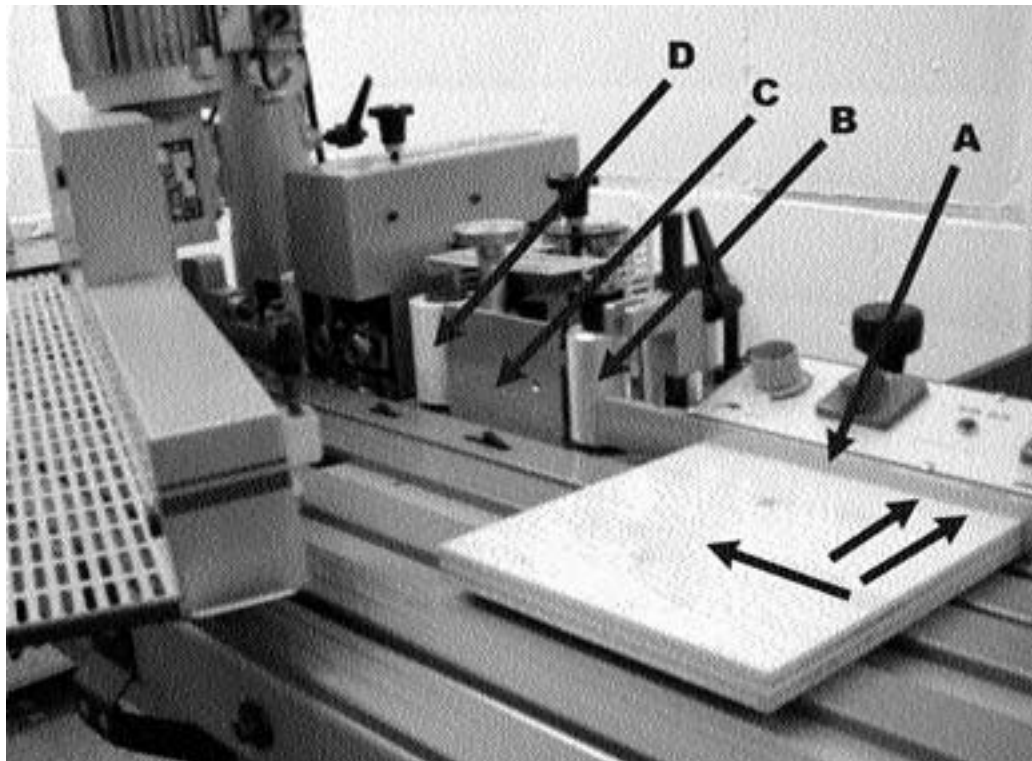

2.3 - Front and back flush trim

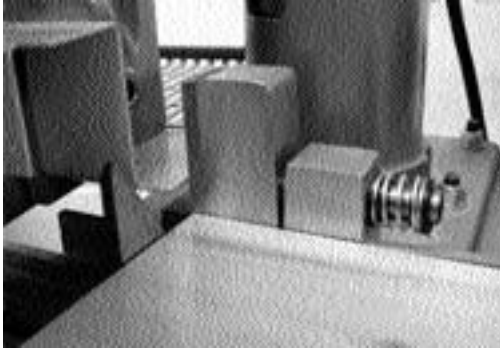

Front cut blade set is located all the way on the left side of the machine under the yellow protective cover. The fixed and stationary blade set are spring mounted on the deck. The moving board will hit the open position movable blade. The whole assembly will then travel 1/8" forward to make sure the board is positioned squarely in the blade set. A micro switch will then activate the magnet set below the deck, the movable blade closes & cuts the tape. You can hear the click from micro switch if you turn the machine off and move the board manually. The front blades cut the tape with melted glue, and should be free of glue build up. If the plastic tape folds rather than getting cut, or if you get excessive glue build up, your temperature might be too high.



The back cut blade set includes a fixed and a movable blade and are under the protective cover as show on the picture. They activate once the board passes over the first micro switch lever on the deck. When the lever pops up, the magnet (located below the deck under the blade) closes the open blade. A spring, under the deck will return the blade back to open position. The back blades are adjustable using the lever located under the deck can be reached from the front of the machine. When changing from wood to plastic tapes, the back blades should be adjusted taking into account the shrink-stretch factor of material tape is made of. To Clean the blades refer to page 6. To reach the magnet or spring go to page 7.

2.4 - Top & bottom motorized flush trim station



This trim station is pre-set at the factory for 3/4" thick board. To adjust for different board thickness, use the top black knob to increase or reduce the distance between the blades. The 2 top and 2 bottom spring loaded guide bearings move the blades according to any slight variations in thickness of the board. A set of scrapers constantly clean the glue off of the bearing guide rollers. Non-stick sprays can be used to keep the blades clean from glue build up. Virutex brand Silicon free spray keeps the blades clean. Silicon free is recommended in case lacquering is needed. It is important to keep the machine clean and blades free of glue build up. The machine also does not have a buffing station, and clean up of glue line may be needed after the edge is banded. Instruction for change of blades / Carbon brushes are shown in the video.

3- Control Panel

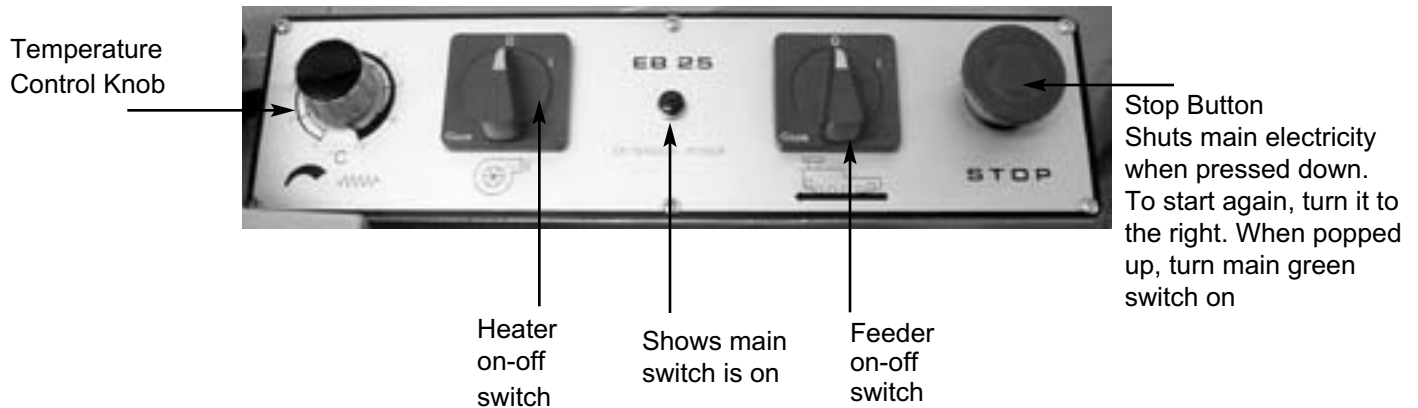

4- Power Feeder

The power feeder is pre-set at the factory for 3/4" thick board.

Height Adjustment

- 1- Unlock feeder using handle on the side of the column.
- 2- Use top handle to adjust height according to scale on the column
- 3- Lock the feeder again

Safety Feature

When swinging open feeder arm, main electrical shuts off.
Restart green main switch.



5- Test run to find the right temperature

Run a board starting at low heat increase temp. to find the best bond

Feeder of EB25 has a constant speed of 15 feet per minute.

Constant speed will reduce the number of variables involved in finding the right temperature for an ideal bond. You need to determine the right melting point for the glue used on your tape. Start with a low temperature of about 250F°, run a board and peel off the tape.

Repeat this step by increasing the temp. by 50F°. Continue the test until you find it hard to peel off, or when peeling the tape, the substrate elements come off too. Allow a few minutes for curing before attempt to peel off the tape.

6- Cleaning the machine

It is essential that edgbanding machines to be cleaned and free of glue build up

Cleaning top+bottom trimming station (time to reach the blades: 5 minutes)

The glue build up occurs on the area of the top and bottom trimming station. The 4 bearing guides are automatically being cleaned by a set of scrapers. The blades need to be cleaned, and covered with a non-stick spray. The glue and material particles can be cleaned away with the air hose

1- To remove trim station,
Take out one screw, loosen
the other, swing away
under mount bracket



2- Take out
trim station



3- Remove 2 covers

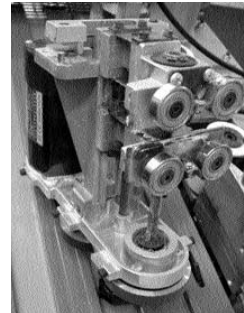

4- Clean top & bottom blades with a brush and solvent. No need to remove blades for cleaning.

Cleaning the front cut blade set (open access)

The front cut blade set located all the way to the left when you face the machine & need to be clean and free of glue build up. Use non-stick spry to keep clean. If there is unusual glue build up on this blades set, your temperature might be too high & over melting the glue. When using plastic tapes, if the excess tape in the front is not cut, but folded on the board, it may be result of excess heat softening tape body and make it hard for the blade to cut.

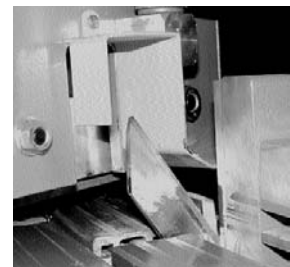

Cleaning the tape infeed track and back end cut blades

(time to reach back blade: 3 minutes)

The glue also **may** build up in this section. If a board enters the power feeder in an incorrect position (explained in page 3) it may cause the tape not to come out in time to be picked up by the board. A piece of tape remains in the infeed track. Remove the tape track assembly, take the tape out & clean the inside tracks with solvent & brush.

How to reach to back blade

The back blade are covered by a protection fence, which is a safety **MUST**.

To reach the blades, remove two parts as follows:

1-Remove the yellow
fence, and air duct
2 screws on top of
yellow fence
1 inside of air duct



2-Remove tape tracking
assembly. 2 crews on
each side of black knob



3- Brush out glue from
top & bottom track
using solvents



4- Clean the back blades.
Do not scrape the blades with
metallic scrapers. Use solvents
and brush. If you need to sharpen
or change the blades, read the
section on changing parts

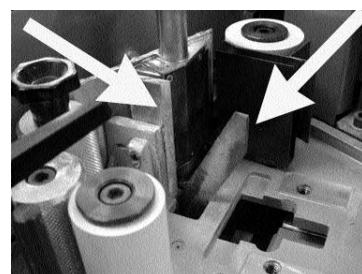

7- Changing Spare Parts

Please use the parts diagram showing exactly how parts are fitted and in what order. If diagrams are missing , we can send it to you as e-mail PDF file, or as fax. Also refer to the repair video

Changing parts in this machine is a lot easier that it appears
All the parts are in easy access position and can be reached with 5 minutes of disassembly. The entire machine can be turned inside out within 15 minutes as shown in the right side picture. The back deck of the machine has 3 sections.

The center section had the back blade assembly system, and the heater under mounted. The left section, the plate under power feeder column, had the front blade assembly under mounted.

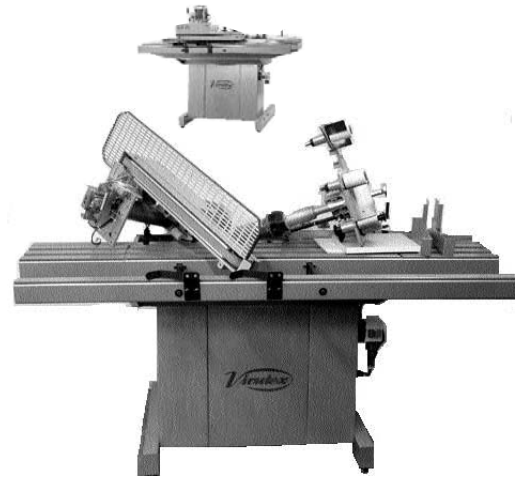

7.2- Top & bottom Trim Station

Take out the trim station, remove the covers (page 6)

Trim Station Carbon Brushes

Remove trim station, remove motor end cover replace carbon brushes



Trim Station Blades

Take out the trim station, remove the covers (page 6)

The best way to see instruction for blade change is to watch the video that is sent with the machine.

Remove trim station, and covers. Remove the screws that hold the blades. Remove the top screws on top of the vertical shaft.

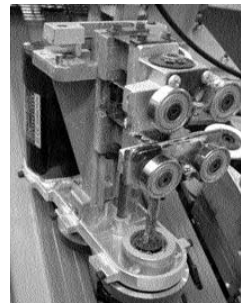

Motor

The motor for the trim station is available as complete assembly of individual components. Refer to parts list/diagram for the trim station. To change the motor or motor components. Remove trim station, remove the covers, the motor ca be taken out by removing top pulley. Or you can take the trim station to any local motor repair shop. We can send any required parts to you or directly to them.

You can also watch the repair video showing how to change the motor

7.3 - Power Feeder Belt

Removing the cover, loosening the main wheel to take out the belt.

The feeder motor is brushless.

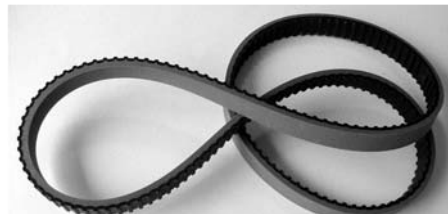

7.4 - To reach the heater, the back cut blades assembly, the magnet, and return spring for the back cut blades, lift up the center plate of the machine per following pictures. All these parts are under mounted to the plate.



Remove the lock knobs of table extension. Remove 4 screws one on top of feeder lock. 2 guide pin hold the base down



Lift up the center plate on deck and turn it over

Magnet for back blades

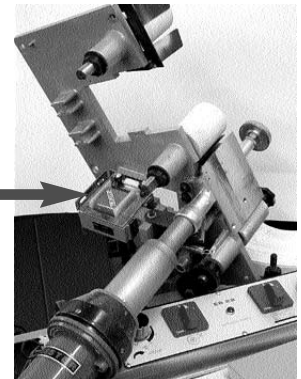

Heater



Blade set: fixed and moveable. They can be resharpened or purchased as a set or individually

Blade return spring

Heater
 The heater can be purchased as one unit or in separate parts

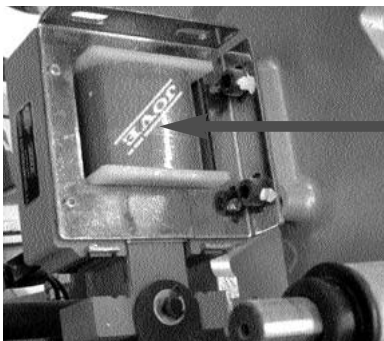

Magnet for back blades

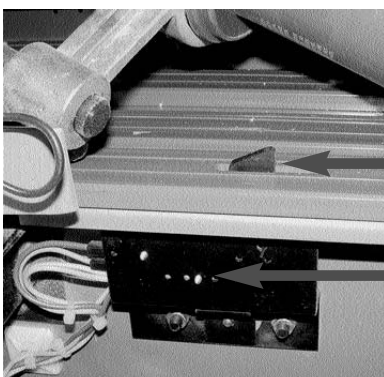

Lever for micro switches that activate the blades. The one all the way to the right activates the back blade once the board passes over and it pops up

Micro switches that activate the blades

7.5 - To Reach Front Cut Blades (on the left when you face the machine) Magnet, Microswitch, & Blade Return Spring

Lift the left section of top deck, under the feeder column, 4 screws, 2 guide pins. Lift the deck and feeder up. Disconnect snap on elect. plug, turn the assembly over to reach above items

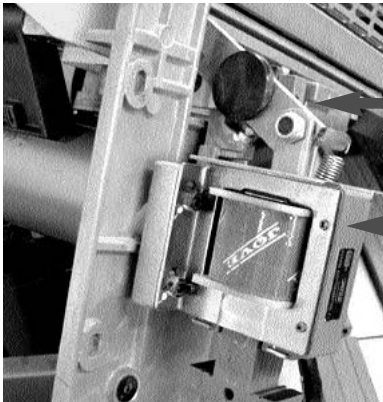
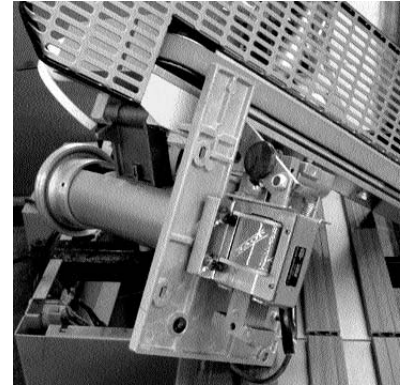
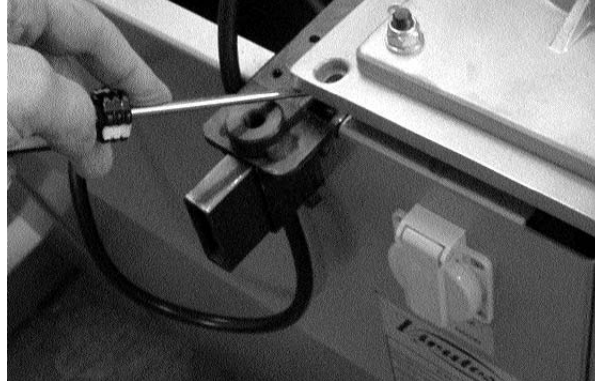

Front cut blade set: Fixed & Movable

Magnet for front cut blade set

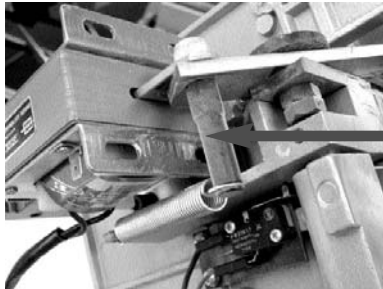

Return spring for front cut blade set



Micro switch to adjust timing of closing of front cut blade set

8 - Trouble Shooting

8.1- If there is no heat

Either the heater (Leister brand) needs a part, or electricity does not get to the heater.

- Heater :You can connect heater direct to see if it works. If it does not, then parts for heater such as blower, motor assembly, electronic circuit, carbon brushes, heating element are available.

- If the heater works independent of machine, then the potentiometer that controls the current to heater might be the cause. To replace, lift the black cap of temp. control knob on panel

Heater can be reached by lifting the center plate of the machine see section 7.4

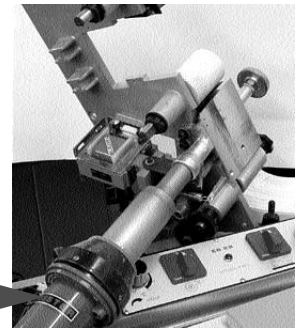

Potentiometer is located under the black cover of the temp.control knob on the left one on the panel



8.2 - If tape does not cover the board

- The tape should be 1/8 wider than the board.

For example, 7/8" wide tape should be used for 3/4" board.

- Plastic tapes under excess heat stretch and their width might be reduced.

In this case the temperature might be too high

- The tape infeed guide might need adjustment to lead the tape on the board in correct position. The black knob is used to make this adjustment. See section 2.2



8.3 - If the front cut has over hang or tape folds over

- If there is excess tape in the front, run a few test board. If still continues, the microswitch under the blade (shown on page 10) need to be adjusted. This is a rare problem, and if it happens, call 1-800-868-9663. A one page instruction+diagram fax will show you how to make this adjustment.

- If the tape folds on the board, there might be too much heat that would make the tape body too soft and hard to cut.

8.4 - When back cut has over hang or is short

There is a small lever located under the front deck of the machine. No section needs to be removed to reach this lever. Just turn the lever to right or left. The back blade is adjustable. Plastic or wood veneer tapes have different stretch factors. So the back cut has to be adjusted once the tape material is changed.

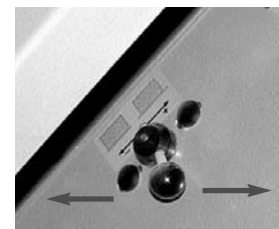
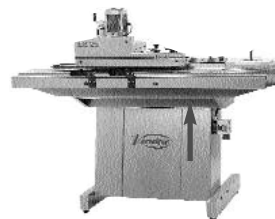

8.6 - When part of the board doesn't get a good bond with tape

If you do not get a good bond in a few inches of the board, and you see that the glue on the back of the tape is not melted. The temperature can not drop that fast in a few seconds

- 8.6 - If any of front or back blades close but do not return back to open position

There glue build up and the blade needs to be cleaned or the return spring is detached see pages 9 and 10 for return springs